

WHE ER 2800 SERIES

EARTH RESISTANCE MONITORING SYSTEM



1. INTRODUCTION

The Earth Resistance Monitoring System, also known as Earth Resistance On-Line Detector (used interchangeably) represents over a decade of dedicated research into grounding resistance detection technology by our experts. This advanced monitoring system has been specifically engineered for continuous on-line monitoring of grounding down-lead connection status, circuit grounding resistance, and metal circuit connection resistance.

The WHE ER 2800B and WHE ER 2800C feature a closed-loop structure requiring interruption of the grounding down-lead during installation. The WHE ER 2800KB and WHE ER 2800KC employ a split-core structure, eliminating the need to interrupt the grounding down-lead, thereby facilitating convenient and efficient installation.

The system provides real-time on-line testing with non-contact measurement. The grounding wire passes through the detector perforation, ensuring no interference with lightning protection effectiveness or normal operations. Data transmission is accomplished via RS485 wired communication or GPRS wireless communication, enabling comprehensive remote on-line monitoring.

The detector incorporates integrated sensors and circuit boards within a completely sealed enclosure, ensuring high accuracy, exceptional stability, and reliable long-term monitoring performance in both field and indoor environments.

Applications

The Earth Resistance On-Line Detector is suitable for:

- Transmission line tower grounding
- Meteorological lightning protection grounding
- Petrochemical grounding systems
- Communication infrastructure grounding
- Substation grounding
- Railway facilities grounding
- Construction and warehouse grounding
- Metal circuit resistance monitoring

- Electrical equipment grounding

System Configuration

The Earth Resistance On-Line Detector may be installed as a standalone unit (C and KC models only) or integrated into wired and wireless network systems.

Wired Network System: Utilises RS485 communication protocol for data transmission. The system comprises the detector, communicator, monitoring software, power adapter, and computer (equipment to be provided by the user for secondary development). Suitable for short-distance ground resistance monitoring.

Wireless Network System: Employs GPRS communication protocol for data transmission. The system comprises the detector (with integrated GPRS transceiver module), SIM communication card, monitoring software, power adapter, and computer (equipment to be provided by the user for secondary development). Suitable for long-distance ground resistance monitoring.

The wired network system is appropriate for monitoring within a 1,500-metre radius, whilst the wireless network system has no distance limitations.

The WHE ER 2800C and WHE ER 2800KC models feature LCD displays for direct measurement data visualisation. The detector incorporates alarm threshold settings with audible and visual alarm indicators, making these models suitable for independent installation without the requirement for network configuration.

Our grounding resistance on-line detector has received explosion-proof certification and complies with the requirements of GB3836-2000 "Electrical Equipment for Explosive Gas Environment".

2. DETECTOR MODEL DISTINCTION

Model	Structure	LCD Display	Audio-Visual Alarm	Alarm Setting	GPRS Communication
WHE ER 2800B	Closed loop	No	Yes	System setting	Optional
WHE ER 2800C	Closed loop	Yes	Yes	Yes	Optional
WHE ER 2800KB	Split core	No	Yes	System setting	Optional
WHE ER 2800KC	Split core	Yes	Yes	Yes	Optional
WHE ER 2800N	Closed loop built-in model	No	No	System setting	Optional
WHE ER 2800T	Closed loop stainless steel housing	No	No	System setting	Optional

Note: Models B and KB require network configuration for operation. Models C and KC may be installed independently or configured within a network system. An optional lightning protection board is available for outdoor lightning-prone environments, compatible with 12V-24V power supplies. 4G and lightning protection boards cannot be purchased simultaneously.

3. TECHNICAL SPECIFICATIONS

Parameter	Specification
Function	Return circuit grounding resistance on-line monitoring, metal return circuit connection resistance on-line monitoring, grounding condition monitoring
CT Structure	Closed loop (B/C models); Split core (KB/KC models)
Power Supply	Detector: 6V DC to 12V DC, 50mA maximum (GPRS 12V DC 150mA maximum). (Ui: 6V; Ii: 50mA; Ci: 0μF; Li: 0mH; Pi: 0.1W) (User supplied). Instrument and safety barrier matching criteria: $U_o \leq U_i$, $I_o \leq I_i$, $P_o \leq P_i$, $C_o \geq C_i$, $L_o \geq L_i$
Resistance Range	0.01Ω~200Ω (WHE ER 2800B/WHE ER 2800C); 0.01Ω~100Ω (WHE ER 2800KB/WHE ER 2800KC)
Resolution	0.001Ω
Accuracy	±2% rdg ±3 dgt (20°C ±5°C, below 70% RH)
CT Size	60mm × 27mm (B/C models); 56mm × 27mm (KB/KC models)
Overflow Indication	B/C models: Test data >200Ω displays "OLΩ" symbol in system software or LCD. KB/KC models: Test data >100Ω displays "OLΩ" symbol in system software or LCD
Connection Cable	1 piece, 1 metre cable (5-core wire)
Connection Identifier	Red/Brown: Power supply input anode; Black: Power supply input cathode; Blue: RS485 signal anode; Grey: RS485 signal cathode; White: Grounding wire shield (Power supply input cathode may be short-circuited with analogue grounding)
Communication Method	Wired network: RS485 communication protocol (supports MODBUS); Wireless network: RS485 or GPRS communication protocol (supports MODBUS)
Network Points	Wired network: 1~250 grounding points, expandable; Wireless network: 60,000 grounding points, expandable
Communication Distance	Wired network: Approximately 1,500m, expandable; Wireless network: Unlimited
Alarm Indication	B/KB models: Detector audio-visual alarm; C/KC models: Detector audio-visual alarm and LCD display
Alarm Setting	B/KB models: System software settings; C/KC models: Detector panel settings, system software settings
Data Display	B/KB models: Not available (connect RS485 interface to read data); C/KC models: 4-digit LCD display (direct reading)
LCD Size	47mm × 28.5mm (C/KC models only)
Dimensions	Detector: 144mm × 130mm × 84mm (B/C models); Detector: 125mm × 119mm × 80mm (KB/KC models)
Weight	Detector: 1.2kg
Operating Temperature and Humidity	-20°C to 55°C; 20% RH to 90% RH
Humidity Error	Within 5%
Ranging	Automatic
Grounding Lead Interference Current	Should be avoided
External Magnetic Field	<40A/m
External Electric Field	<1V/m
Single Measurement Time	Approximately 0.5 seconds
Operating Current	Detector: 50mA maximum (GPRS: 12V DC 150mA maximum)
Explosion-Proof Marking	Ex ia IIB T3 Ga
Explosion-Proof Certification	CE23.3868X
Protection Level	IP65
Power Supply Mode	External power supply (user supplied)
Regular Version 4G	LTE-FDD: B1/B3/B5/B8; LTE-TDD: B34/B38/B39/B40/B41
Global Version 4G	LTE-FDD: B1/B2/B3/B4/B5/B7/B8/B12/B13/B18/B19/B20/B25/B26/B28; LTE-TDD: B38/B39/B40/B41; WCDMA: B1/B2/B4/B5/B6/B8/B19; GSM: B2/B3/B5/B8
Ground Current Measurement (Optional)	Range: AC 0.0mA to 20A; Resolution: 0.1mA; Accuracy: ±2% rdg ±5 dgt

4. DETECTOR STRUCTURE

4.1 WHE ER 2800B/WHE ER 2800C

Component Identification:

- 4.1.1. Clamp tester aperture: 60mm × 27mm
- 4.1.2. Indicator light
- 4.1.3. LCD display
- 4.1.4. Mounting screws: Φ7mm
- 4.1.5. Control buttons
- 4.1.6. Power supply and RS485 interface

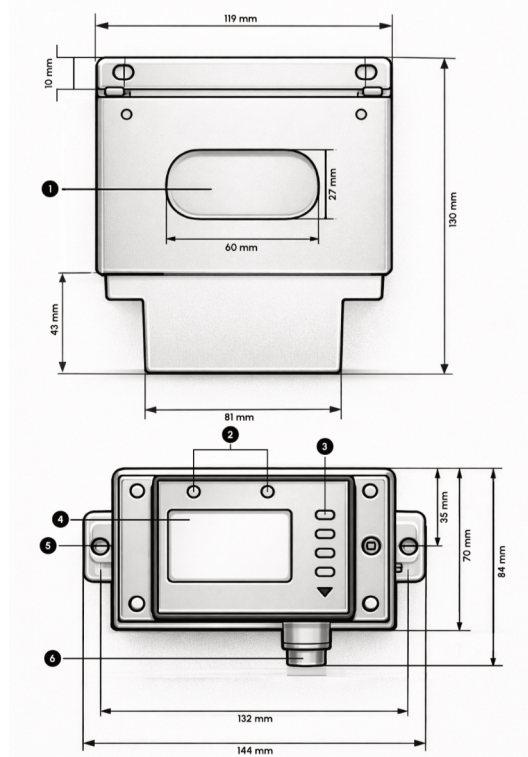

4.2. WHE ER 2800KB/WHE ER 2800KC

Component Identification:

- 4.2.1. Grounding wire perforation: 56mm × 26mm
- 4.2.2. Indicator light
- 4.2.3. LCD display
- 4.2.4. Control buttons
- 4.2.5. Installation hardware
- 4.2.6. Mounting screws: M5 × 8mm (2 pieces)
- 4.2.7. Detector front component
- 4.2.8. Detector rear component
- 4.2.9. Front and rear connection screws: M5 × 55mm (2 pieces)
- 4.2.10. Power and RS485 communication interface

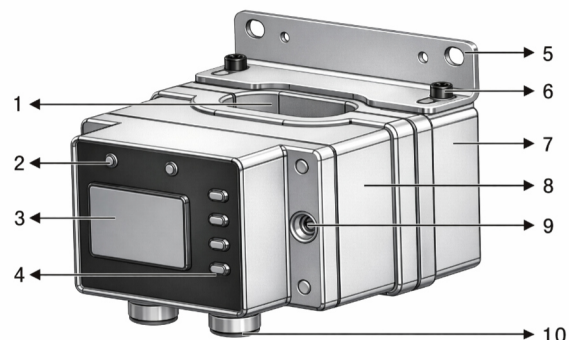

Indicator Functions:

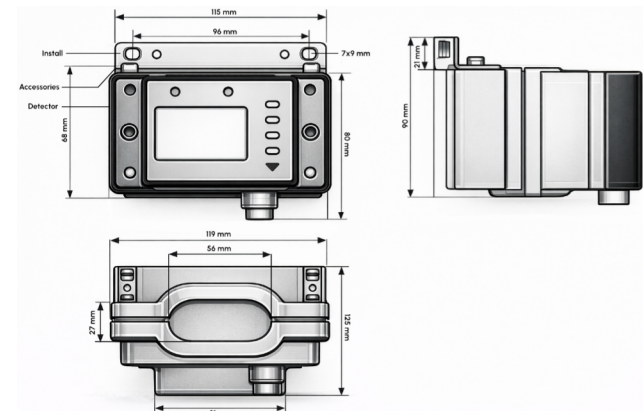

Indicator	Function
POWER indicator	Power indicator; illuminates when power is supplied and display is active.
ALARM indicator	Alarm indicator; flashes when the measured value exceeds the configured threshold.
SET button	Enters settings mode.
Up/Down buttons	Used within settings mode to adjust values. Press SET to enter alarm settings, then use Up/Down buttons to modify data.
ENTER button	Confirms and saves alarm threshold settings after configuration.

Note: The WHE ER 2800B/WHE ER 2800KB models feature alarm indicators only, without LCD displays or button functions.

5. WHE ER 2800C/2800KC LCD DISPLAY

Display Elements:

- 5.1. Alarm symbol
- 5.2. Low battery symbol
- 5.3. Data storage number
- 5.4. Measurement value display
- 5.5. Resistance unit symbol

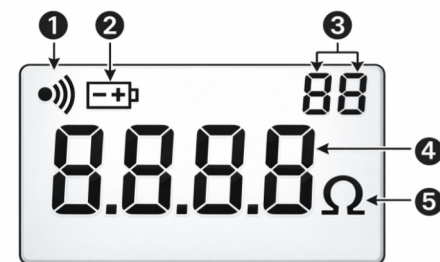

6. NETWORK STRUCTURE

6.1. Independent Installation

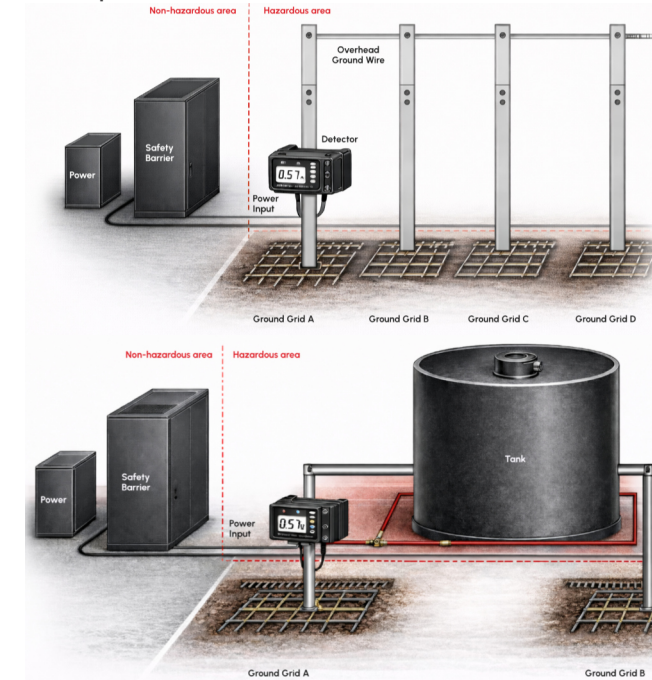

The WHE ER 2800C/WHE ER 2800KC models may be installed independently or integrated into a network system. The LCD displays measured values directly. Alarm thresholds can be configured via the detector, providing audio-visual alarm functionality.

6.2. Wired Network System (Self-Exploitation Software)

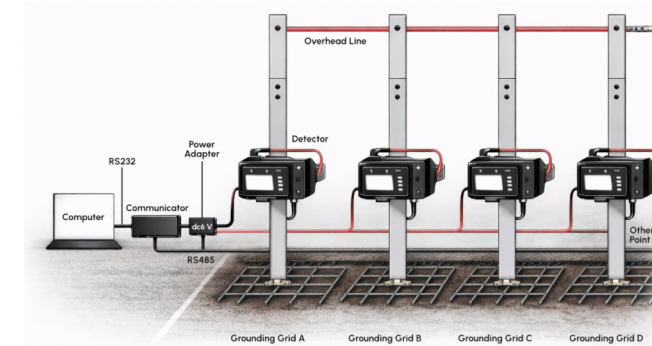

The wired network system employs RS485 communication protocol for data transmission. The system comprises the detector, communicator, monitoring software, power adapter, and computer (user-provided equipment requiring secondary development). This configuration is suitable for ground resistance monitoring within a 1,500-metre radius.

6.3. Wireless Network System (Self-Exploitation Software)

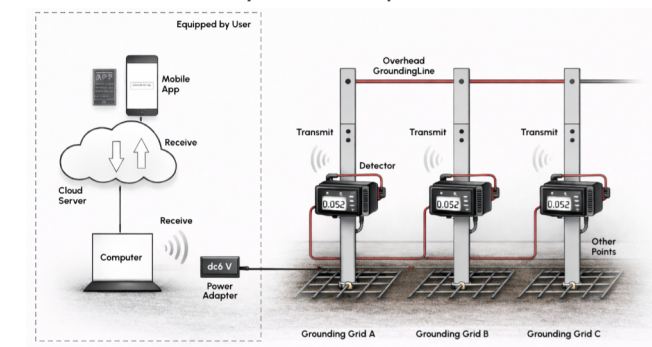

The wireless network system utilises GPRS communication protocol for data transmission. The system comprises the detector (incorporating an integrated GPRS transceiver module), SIM communication card, monitoring software, power adapter, and computer (user-provided equipment requiring secondary development). This configuration is suitable for long-distance ground resistance monitoring without distance limitations.

7. OPERATING PRINCIPLE AND APPLICATION

7.1. Testing Principle

The fundamental operating principle of the Earth Resistance On-Line Detector is loop resistance measurement. The sensor transmits a drive pulse signal to the measured ground return circuit. This circuit responds with a pulse electromotive force (E), which generates current (I) within the measured ground return circuit. The sensor measures both E and I values, calculating the resistance value of the measured ground return circuit using the formula: $R = E/I$.

7.2. Loop Resistance Definition

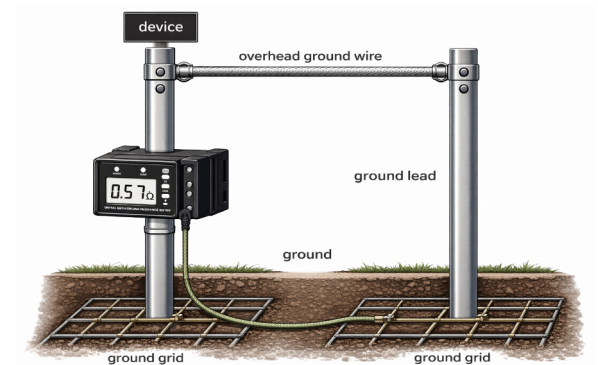

Loop resistance represents a composite value encompassing:

- Point A grounding resistance value
- Grounding down-lead metallic conductor resistance value
- Metal overhead line resistance value
- Connection resistance value (contact resistance) between grounding down-lead and metal overhead line
- Point B grounding resistance value

For grounding systems already configured as loops, the detector may be installed directly for monitoring purposes. For systems not configured as loops, an auxiliary grounding electrode must be added to form a loop circuit before detector installation. Please refer to Section 7.4 (Single Point Grounding System) for further guidance.

If the detector measures a composite loop circuit value of 5.0Ω for grounding grid A and grounding grid B, the actual grounding resistance value of grounding grid A in parallel connection with grounding grid B must be less than or equal to 2.5Ω [calculated using the formula $R = RA \times RB / (RA + RB)$]. This calculation enables assessment of whether the actual grounding resistance value of the parallel-connected grounding grids A and B meets qualification criteria.

If the combined grounding resistance value of grounding grid A and grounding grid B is less than the engineering standard requirement, both grounding grids A and B may be deemed qualified.

7.3. Metal Return Circuit Connection Resistance Testing

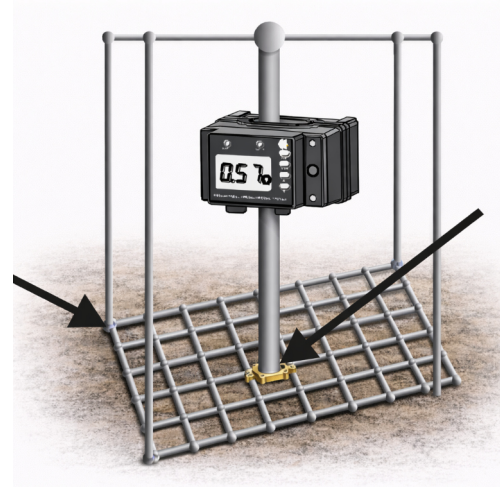

When grounding network A and grounding network B are connected above and below ground level, the detector typically measures very low resistance values in the metal return circuit, generally a few ohms or less than one ohm. This represents the connection resistance of the metal return circuit, functioning as equipotential resistance rather than grounding resistance. Consequently, the detector provides exceptional capability for testing metal return circuit connection resistance.

In large-scale grounding grids, such as those found in converter stations, oil depots, building construction sites, and similar installations, an integral grounding grid exists beneath the surface with numerous grounding down-leads extending to ground level and interconnected. For such large-scale grounding grids, where the maximum diagonal distance may span several hundred to thousands of metres, testing grounding resistance presents significant challenges.

Should grounding resistance prove unsatisfactory, the issue typically manifests at the connection point between the grounding down-lead and the grounding grid (indicated by arrow directions at welding positions in diagrams). Engineering remediation requires excavation and re-welding of the grounding down-lead position. Complete grounding grid reconstruction, necessitating demolition and rebuilding of surface facilities, is impractical.

Therefore, for large-scale grounding grids, detectors should be installed on primary and secondary grounding down-leads to monitor connection status between grounding down-leads and the grounding grid. Grounding conditions of the grounding down-lead are assessed by testing metal return circuit connection resistance.

7.4. Single Point Grounding System

When grounding network A and grounding network B lack overhead line connectivity and are not interconnected at ground level, both networks may be regarded as standalone single-point grounding connections. The detector cannot directly test single-point grounding system resistance; an "OL" overload symbol will be displayed. Consequently, one or more auxiliary grounding electrodes must be added to form a multipoint return circuit before detector installation.

Within limited areas containing two or more single-point grounding systems, metallic conductors may be used to interconnect all single-point grounding system down-leads at ground level, forming a return circuit. The detector may then be installed for monitoring purposes.

7.5. Three-Point Method

In the configuration illustrated, the tested ground pole is designated A, with auxiliary ground poles designated B and C. Poles A, B, and C are interconnected at ground level. Detectors installed on the three ground

pole down-leads enable accurate testing of ground point A resistance value, calculated as follows:

$$R_1 = RA + RB // RC \text{ ----- (1)}$$

$$R_2 = RB + RA // RC \text{ ----- (2)}$$

$$R_3 = RC + RA // RB \text{ ----- (3)}$$

Where R_1 , R_2 , and R_3 represent detector test results, and RA, RB, and RC represent grounding resistance values of the three grounding poles. By solving these three simultaneous equations, the grounding resistance of the measured grounding pole RA may be accurately determined. The grounding resistance values of auxiliary grounding poles RB and RC, as well as the parallel-connected grounding resistance of RA, RB, and RC, become known values.

The three-point detection method offers an additional advantage: the parallel connection of auxiliary poles B and C to measured ground pole A results in actual grounding resistance less than RA, thereby improving the effectiveness of the measured ground pole: $RA // RB // RC < RA$.

In practical implementation, auxiliary grounding pole B and C grounding resistance requirements should remain within ten times the grounding system engineering standard. For projects requiring grounding resistance not exceeding 4Ω , $RC < 40\Omega$ and $RB < 40\Omega$. Lower RB and RC values provide greater improvement to the measured grounding system.

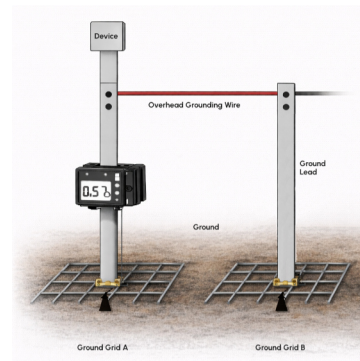

7.6. Application

7.6.1. Power Transmission System Pole Grounding

Multipoint grounding systems formed through overhead ground wire connections facilitate convenient testing. The equivalent circuit is as follows:

Explanation: R_1 represents predicted grounding resistance. R_0 represents the parallel-connection equivalent resistance of all other pole grounding resistances: $R_0 = R_2 // R_3 // R_4 // \dots // R_n$. As n increases (more grounding poles), R_0 approaches zero, becoming substantially smaller than R_1 . From an engineering perspective, $R_0 = 0$; therefore, data received from the detector approximates the value of R_1 .

Detectors may be installed on each tower, enabling simultaneous testing of tower grounding resistance.

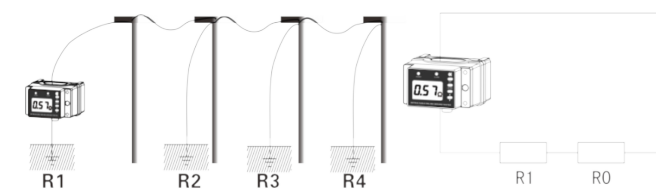

7.6.2. Generator Room and Launch Tower Grounding

Engine rooms and tower grounding installations are typically independent field installations. They may be interconnected to form a two-point circuit before detector installation, or two auxiliary grounding poles may be created to establish three-point monitoring.

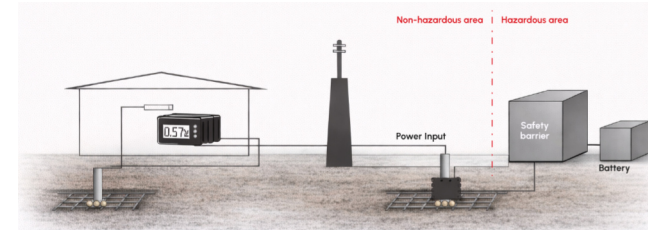

7.6.3. Building Grounding

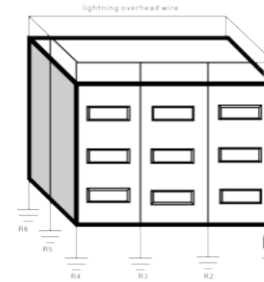

If R_1 through R_n represent independent grounding bodies beneath the surface without interconnection as a multipoint grounding system, grounding resistance testing is straightforward. If R_1 through R_n are interconnected beneath the surface as a single-point grounding system, grounding resistance should be tested according to single-point grounding system methodology. Direct installation enables testing of metal return circuit resistance, facilitating assessment of grounding connection conditions.

For large-scale construction grounding grids, equipotential values of grounding conditions between grounding down-leads and grounding networks may be monitored. Should issues arise, they will manifest at connection points between grounding down-leads and grounding networks. Therefore, testing and assessment of equipotential value qualification suffices.

7.6.4. Oil Storage Tank Loading and Unloading Point Grounding

According to JJF2-2003 "Ground-Based Anti-Static Device Testing Norms", petrol stations require testing of main facility grounding resistance and connection resistance.

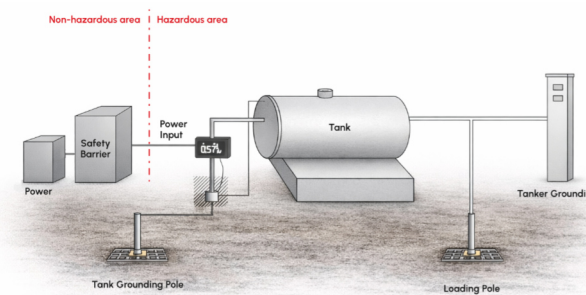

8. Wiring Instructions

Equipment	Wire Color	Connection instructions
Detector	Red/Brown	Power supply input anode
	Black	Power supply input cathode (GND)
	Green	RS485 Signal Positive Electrode
	Yellow & Green	RS485 Signal Negative Electrode
	White	Signal grounding electrode (may be short-connected to GND)

When establishing network configuration, connect the detector, communicator, and power supply according to wire colour coding.

The detector commences operation upon power supply connection. External power supply installation should incorporate a power switch.

9. WHE ER 2800KB/WHE ER 2800KC INSTALLATION DIMENSIONS AND PRECAUTIONS

9.1. Installation Method

Closed-Loop Detector Installation: Installation of the closed-loop grounding resistance on-line detector requires interruption of the ground down-lead. Installation may be performed on ground flat steel or directly on a backplane.

Split-Core Detector Installation: Installation of the split-core grounding resistance on-line detector does not require interruption of the grounding down-lead. The detector includes hardware mounting components with two installation options: ground flat steel mounting or direct backplane mounting.

During installation:

1. Determine the installation location
2. Assemble and secure the hardware to the rear component
3. Loosen the core fastening screws
4. Insert the grounding lead wire into the detector
5. Tighten the core fastening screws

9.2. Installation Dimensions

9.2.1. Installation on Ground Flat Steel

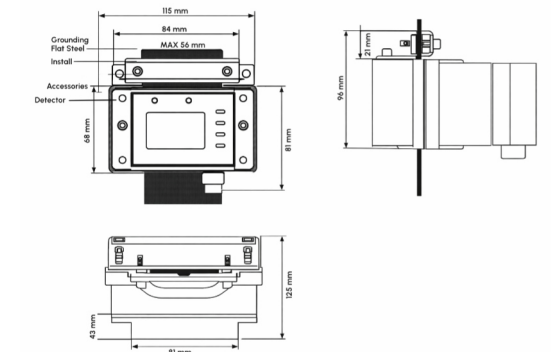

9.2.2. Installed on the backplane

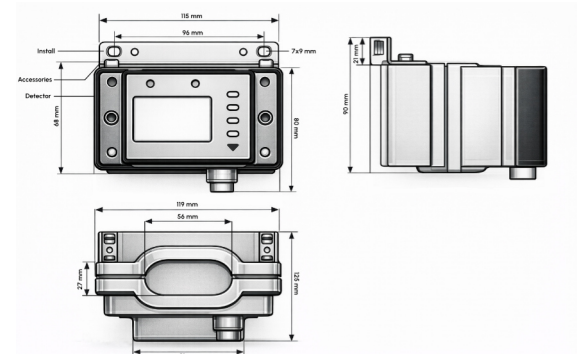

9.3. Installation Precautions

9.3.1. During installation, maintain cleanliness of upper and lower magnetic ring surfaces. All detector upper and lower fixing screws must be securely tightened.

9.3.2. Each detector's upper and lower assembly components are factory-matched pairs and must not be exchanged with components from other detectors during installation. Matched device components incorporate unique codes. Verify code consistency during installation.

9.3.3. **Critical:** Only grounding systems configured as loops may be installed and operated directly. For grounding systems without loops, auxiliary ground poles must be established near the tested ground pole.

Connect a loop from the tested grounding pole to the auxiliary ground pole before detector installation.

9.3.4. According to site distance requirements, connect power and communication lines to the communicator, detector, and power supply.

9.3.5. Communicator and detector wiring must correspond correctly. Power cables are strictly prohibited from accessing RS485 signal lines, as this will damage the instrument.

9.3.6. Communicator and detector connection distance must not exceed 1.5 kilometres.

9.3.7. Power cable positive and negative connections must not be reversed; otherwise, the system will not function.

9.3.8. Wireless communicator antennae must be positioned externally and must not be placed within shielding enclosures.

9.3.9. SIM Communication Card Installation: Before use, install the SIM communication card. Installation must not occur whilst powered. This operation must be performed by professional engineering and technical personnel. As the GPRS transmitter module is integrated within the communicator, the communicator must be opened to install the SIM communication card. (GPRS models only)

10. POWER SUPPLY MODEL SELECTION

10.1. External Power Supply (Self-Provided)

External AC 220V power is conducted to the vicinity of the detector or communicator via power adapter to supply the detector and communicator. For external DC 9V power supply, connect directly to the detector and communicator.

10.2. Battery Power (Self-Provided)

Battery-powered detector and communicator power supply. Two batteries may be maintained on standby, alternating usage at intervals.

10.3. Solar Panel Power (Self-Provided)

As illustrated, solar panels, protective enclosures, and batteries may be procured for locations where mains power is unavailable. Batteries are housed within protective enclosures. The solar cell positive electrode and battery positive electrode require connection via a positive diode (such as IN5817) for rapid connection. This configuration is particularly convenient for independent WHE ER 2800KC operation.

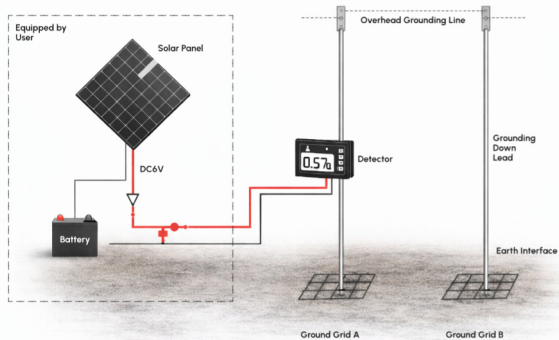

Note:

- Detector power supply: DC 6V to DC 12V
- Wired network communicator power: DC 9V
- Wireless network communicator power: DC 12V

11. WIRED MONITORING SOFTWARE (SELF-EXPLOITATION SOFTWARE)

Users may employ debug wizards downloaded from the internet to configure ports and addresses, verifying proper detector communication. Secondary development may be undertaken according to operational environment requirements to customise software functionality.

12. WIRELESS MONITORING SOFTWARE (SELF-EXPLOITATION SOFTWARE)

Detector configuration software is utilised to configure wireless parameters, including IP and port numbers. The detector reports data via the GPRS module. Users may perform secondary development according to operational environment requirements to customise software functionality.

Note: The data receiving terminal must be a computer or server with a fixed IP address.

13. BASIC CONFIGURATION

Component	Quantity	Notes
Detector	1 piece	
Installation Hardware (2 pieces)	1 set	WHE ER 2800KB / WHE ER 2800KC
Hardware Fixing Screws M5 × 8mm	2 pieces	
Flat Steel Compression Screw M5 × 35mm	2 pieces	
Allen Wrench	1 piece	
Cable	1 piece	
GSM Glue Stick Antenna (4G version accessory)	1 piece	
Packaging	1 set	
User Manual, Warranty Manual, Certificate	1 set	

14. STRATEGIC BENEFITS AND VALUE PROPOSITION

The WHE ER 2800 Series transforms electrical safety infrastructure management from reactive maintenance to proactive monitoring, delivering measurable improvements in operational efficiency, safety compliance, and total cost of ownership whilst reducing organisational exposure to catastrophic failure events.

Elimination of Manual Testing Requirements

Traditional earth resistance testing requires periodic manual measurement by qualified personnel, typically on monthly cycles. The WHE ER 2800 Series eliminates this requirement entirely, liberating technical staff for higher-value activities whilst ensuring continuous monitoring integrity exceeds that achievable through intermittent manual testing. Human error in measurement and documentation is eradicated, and supervisory inspection burdens are substantially reduced, particularly beneficial for geographically dispersed installations.

Predictive Maintenance Capability

Continuous monitoring enables organisations to detect deteriorating earth resistance conditions before they precipitate equipment failure. This supports transition from breakdown maintenance to condition-based maintenance protocols, materially reducing unplanned downtime and extending asset service life. Real-time data availability enables predictive maintenance scheduling, minimising emergency interventions and optimising maintenance resource deployment.

Enhanced Personnel Safety

Electrical hazards and fire incidents frequently originate from degraded earthing systems exhibiting high earth resistance, disconnected earth conductors, or elevated contact resistance. The WHE ER 2800 Series' contactless measurement technology eliminates personnel exposure to electrical hazards during testing whilst providing continuous surveillance against the progressive failures that precede incidents. This represents a fundamental improvement in workplace safety protocols.

Lightning Protection Assurance

During surge and lightning events, voltage magnitudes are substantial and allowable dissipation timeframes are measured in microseconds. Analysis of lightning-related fire incidents reveals that inadequate earth resistance maintenance represents a primary contributing factor. Continuous monitoring through the WHE ER 2800 Series eliminates unexpected high-resistance surprises, ensuring protective systems function as designed when required, critical for asset protection and operational continuity.

Regulatory Compliance and Governance

Earthing arrangements constitute fundamental safety infrastructure protecting both personnel and assets. Continuous on-line monitoring facilitates demonstration of due diligence and provides auditable evidence of ongoing compliance with electrical safety standards. This supports organisational governance requirements and demonstrates commitment to best-practice safety management, particularly valuable during regulatory inspections and insurance assessments.

Material and Component Longevity

Stray current, a consequence of elevated earth resistance, accelerates metallic component corrosion. By maintaining earth resistance within specified parameters, the WHE ER 2800 Series reduces stray current, directly extending the service life of earthing system components including earth pits, electrodes, connectors, bus bars, and cables. This translates to extended replacement intervals and reduced procurement costs over the system lifecycle.

Incident Cost Avoidance

Prevention of accidents, equipment failures, and breakdown maintenance events delivers substantial financial benefit. The WHE ER 2800 Series enables organisations to avoid costs associated with emergency repairs, production downtime, equipment replacement, personnel compensation claims, and insurance premium increases. For critical infrastructure applications, preventing a single catastrophic failure event typically justifies the entire monitoring system investment.

Continuous Real-Time Monitoring

Unlike manual testing methodologies that provide periodic snapshots, the WHE ER 2800 Series delivers continuous real-time resistance values with measurement intervals of approximately 0.5 seconds. This enables immediate detection of degradation trends and threshold violations, allowing intervention before conditions become critical. The system provides unprecedented visibility into earthing system performance characteristics that intermittent testing cannot achieve.

Complete Loop Resistance Assessment

The system measures complete loop resistance including all contact points in a single measurement cycle, eliminating the need for separate contact resistance verification. This provides comprehensive assessment of earthing system integrity, detecting issues at connection points that might be missed by conventional testing methods. For large-scale grounding grids, this capability is particularly valuable in monitoring equipotential bonding effectiveness.

Non-Intrusive Installation

Split-core models (WHE ER 2800KB/KC) enable installation without interrupting grounding conductors, facilitating deployment on energised systems without operational disruption. This represents a significant advantage over conventional testing methods requiring system isolation or disconnection. Installation can proceed during normal operations, eliminating downtime and production losses associated with testing activities.

Scalable Architecture for Any Organisation

System architecture supports configurations from single-point standalone installations to enterprise-scale networks monitoring thousands of locations. Wired networks (RS485) support up to 250 monitoring points within 1,500-metre radius; wireless networks (GPRS) support up to 60,000 monitoring points without distance constraints. This flexibility accommodates organisations at any scale, from single-facility operations to geographically distributed enterprises.

Integration with Existing Systems

RS485 and GPRS communication protocols with MODBUS support enable seamless integration with existing building management systems, SCADA platforms, and enterprise asset management systems. This allows organisations to incorporate earth resistance monitoring into established operational frameworks without requiring parallel systems or duplicate interfaces. Data flows into existing reporting structures and alarm management protocols.

Environmental Resilience for Demanding Applications

With IP65 protection, explosion-proof certification (Ex ia IIB T3 Ga), and operational temperature range from -20°C to 55°C, the system is engineered for reliable performance in demanding industrial environments. This includes petrochemical facilities, outdoor transmission infrastructure, and harsh climate conditions. The sealed construction ensures long-term reliability without degradation from environmental exposure.

15. PRECAUTIONS FOR USE

Thank you for selecting the WHE ER Grounding Resistance On-Line Detector. To ensure optimal performance and safety, please note the following:

- Read this user manual thoroughly before installation and operation.
- Comply with all operating instructions and safety precautions outlined in this manual.
- Applicable to loop circuit ground resistance, metallic loop circuit bonding resistance, and grounding conditions on-line monitoring.
- Single point grounding systems require the addition of an auxiliary earth pole to form a loop circuit before detector installation.
- Ensure operation within the specified measurement range and environmental conditions detailed in this manual.
- The detector comprises split-core and closed-loop structures. The front and rear components are factory-matched pairs and must not be interchanged with components from other detectors, as this will significantly compromise measurement accuracy. Before installation, verify that the matched device part codes are identical.
- During installation, ensure that both front and rear detector surfaces are clean. Firmly secure and tighten all screws.
- When deploying in hazardous locations, the external power supply connected to the detector must be routed through an appropriate safety barrier. The safety barrier must be positioned in a non-hazardous area.
- The product housing is manufactured from non-metallic materials; electrostatic charge accumulation may occur. Avoid friction in hazardous areas. Clean only with a damp cloth.
- Disassembly, calibration, and maintenance of the detector must be performed exclusively by authorised personnel.
- Should the instrument become dangerous to continue using due to any defect, operation must cease immediately. The equipment must be sealed and handled by an authorised institution.